

VisabollTM

Retroreflective Self-righting Bollard Fixing options

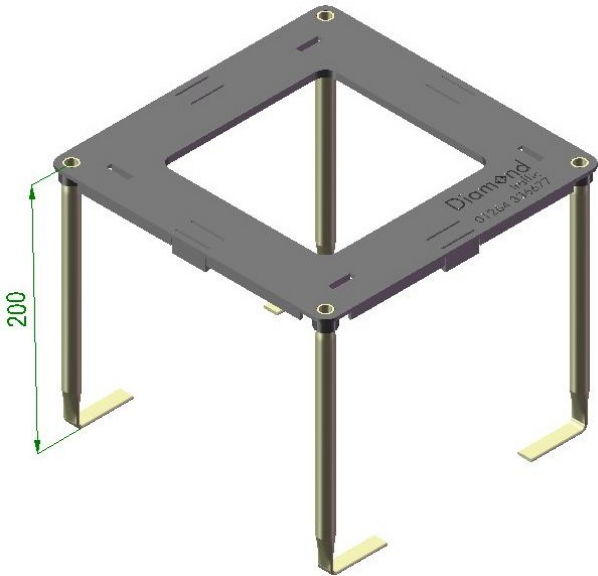

GROUND CAGE

Visaboll anchor fixing into new concrete foundations. Threaded tubes come flat packed into carrier moulding for ease of storage and transportation. Before installing into the excavated site the tubes are plugged into the moulded corner sockets. Concrete should come level with the top surface of the moulding. This system of fixing ensures a metal to metal contact throughout the securing line thus preventing the potential problems caused by plastic expansion and contraction.

Part number: 8879

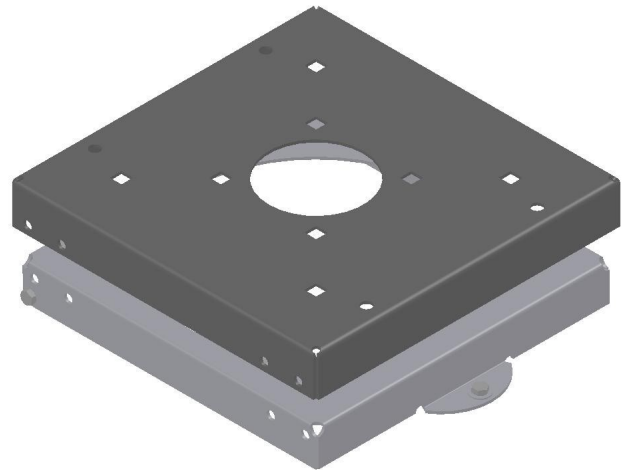

LIGHT-BOX ADAPTOR PLATE

Converts redundant fixings used for an illuminated bollard into fixings suitable for the Visaboll assembly. The assembly is designed and supplied with appropriate fixings to fit all common types of light box.

Part number: 8878

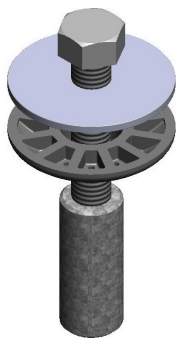

VISABOLL SPARES FIXING KIT

Comes with:

4 off M10 x 65mm long stainless steel screws, plastic domed washers, spread washers and compression stop tubes.

Part number: 8898



ANCHOR BOLT FIXING KIT

Bolt down fixing for existing concrete foundations. Kit comes with 4 off standard anchor bolts fitted with stainless steel bolts to suit the Visaboll assembly.

Part number: 8899